



5
YEAR
WARRANTY

Hawk & IRWL Complete System

Hawk Crosswalk Systems
don't target distracted drivers...
...UNTIL NOW

Nothing compares to a LaneLight IRWL system when you target the tunnel vision of a Distracted Driver. Maximize the visibility of your HAWK crosswalk systems with a dual color LaneLight In Road Warning Light system. Seamless traffic controller integration...

Dramatically Enhanced VISIBILITY!

SPECIFICATIONS

Hawk & In-Road Warning Lights

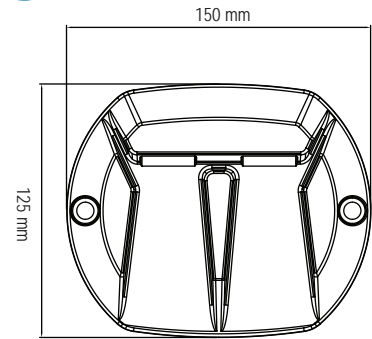
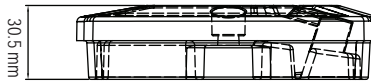
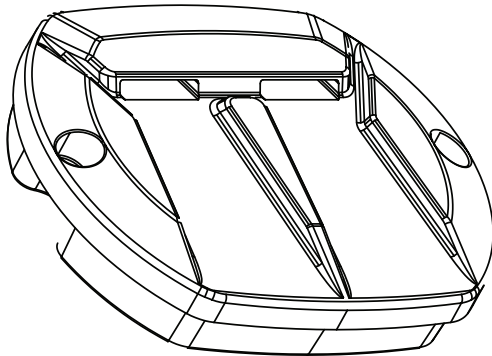

SPECIFICATIONS

Dimensions -LED module	150mm x 125mm (5.9" x 5")
Dimensions - Housing	175mm (7")
Protrusion from pavement	3 mm (.12") or Flush Mount option
Housing depth (incl.sub base)	65mm (2.56")
Daytime visible	3,000ft (dimmbable by PWM at night)
Snowplowable	Yes, with Flush Mount option
Housing - LED module	Stainless Steel
Housing	Aluminum
Sealing	IP68
Load rated	5,000 kg compression
Operating temperature	-20C to +50C
Lens	Boron / glass
LED face	Uni-directional
LEDs per unit	16
LED color	Dual color fight head - Amber and Red
Activation	Integration with H.A.W.K. controller
Power	Hardwired; Low voltage AC 2.5w (nominal)
Controller	Microprocessor, (sold separately)
Wiring	18 AWG direct burial or drain equipped conduit 2 or 3 wire configurations

